

**ISOTECH**

✓ The Source for Calibration Professionals



The new **microK** family  
of precision thermometry bridges

**Unequaled combination  
of Accuracy, Stability  
and Versatility**

[www.isotechna.com](http://www.isotechna.com)

# Introduction

The microK family of precision thermometry bridges use a completely new measurement technique to achieve accuracies to better than 0.02ppm.

With four models to suit all levels of temperature metrology from National Measurement Institutes to those wanting a solution to make low uncertainty temperature measurements in a range of applications.

In addition to making the best resistance measurements the microK makes high accuracy thermocouple measurements with a voltage uncertainty of <0.25µV. The microK can be used with all standard

thermometer types including SPRTs, Standard Thermocouples, Industrial PRTS and thermistors.

First introduced in 2006 the microK has proven use at the world's leading NIMs and many commercial laboratories. After years of experience and success we now introduce new models with even better performance and new features. All microK models now include IEEE-488 General Purpose Interface Bus as well as RS232 and USB. The microK 70 and microK 125 also feature an Ethernet port and can be monitored and controlled across a LAN.

# Performance by Design - Drift Free

"Performance by Design" was the mantra and passion behind the development of the microK. On Day 1 a decision was made, "no tweak pots" (such as used on AC Bridges to correct for flux leakage), no software adjustment, no "self-calibration" but performance by design. The microK achieves its resistance ratio accuracy by design, not adjustment and is uniquely drift free.

To be clear, as a ratio bridge the microK is drift free. This is a benefit of the substitution topology used and provides one of the microK's most exciting features, it is inherently drift free.

It doesn't have compensation or adjustment circuits, it doesn't have software offsets, it doesn't self-calibrate, it never needs adjusting, never needs a service engineer, in ratio measurement it is drift free by design.

For more details read, "Using a Substitution Measurement Topology to Eliminate the Effect of Common Mode Errors in Resistance Measurements used in Temperature Metrology" available on the Isotech Website which also explains why the performance of the microK is superior to DC potentiometric instruments.

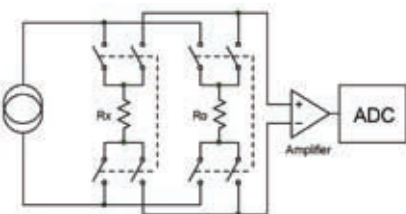

Principle of the microK Substitution Topology

# Applications

- ITS-90 Fixed Point Calibration
- Comparison Calibration of Standard Thermometers
- Oceanographic
- Aerospace
- Pharmaceutical
- Research

# Key Features

## Accuracy

| Model      | Ratio Accuracy ppm* | Accuracy (Whole Range) ppm |
|------------|---------------------|----------------------------|
| microK 70  | 0.017               | 0.07                       |
| microK 125 | 0.03                | 0.125                      |
| microK 250 | 0.06                | 0.25                       |
| microK 500 | 0.125               | 0.5                        |

### ■ Resistance Thermometry

- 0.1Ω, 0.25Ω, 1Ω, 10Ω, 25.5Ω, 100Ω SPRTs
- Industrial PRTs
- Thermistors

### ■ Voltage Measurement

- Laboratory Standards: Platinum / Rhodium, Platinum / Gold and Base Metal, Accuracy to 0.25µV

### ■ Display Modes

- Numeric and Graphical
- Ratio, Resistance, Voltage, °C, °F, K

### ■ Stable

- ZERO drift in ratio measurement

### ■ Three Input Channels - Best

- Practice Ready
- Expandable to 92

### ■ Ease of Use

- Intuitive Touch Screen Operation, Store all Standard Thermometer and Standard Resistors internally
- Log to internal memory or USB Memory Drive

### ■ Reliable

- 21st Century Solid State Design, no moving parts

\* At Ratio: 0.95 to 1.05



# Performance by Design - More Advantages

In making ratio measurements other benefits by design include:-

- **Zero Hysteresis**  
There is no hysteresis effect by design
- **Zero Channel to Channel Variation**  
Even with a microsKanner, as the channel expander duplicates the front end of the microK for each input rather than just being a switch box
- **Zero Temperature Coefficient**  
Temperature Coefficient is 0ppm/°C, another benefit of the substitution technique. No need for warm up or stabilisation periods.
- **Complete Line Frequency Rejection**  
Total rejection of 50 and 60Hz line frequency

## ADC

The microK realises its superior linearity and low noise through a number of novel approaches, including a new noise reduction technique, new solid state switching, new guarding arrangements and a sophisticated substitution topology to achieve zero drift.

So perhaps it will be of no surprise to learn it also uses a new type of ADC, the concept for the core ADC technology was licensed from NPL (the UK's national standards laboratory) and operates under NPL's "Technology Applied" scheme.

It is a unique adaptation of the established sigma-delta technique, different in that it uses a 5-bit DAC in place of the 1-bit DAC in the control loop. This would not normally be feasible, since the DAC would 'carry' the full accuracy burden of the measurement. However, the microK 100 ADC uses pulse-width-modulation (PWM) to generate the 5-bit signal thereby converting the analogue signal requirement into one of timing. In order to achieve our target of <0.05ppm, we needed to be able to produce pulses whose edges have relative timing errors of

0.5ps (about the time it takes light or electrical signals to travel 0.15mm).

For more information see "Better Accuracy in Temperature Calibration and Measurement through a New Type of Analog-to-Digital Converter" available on the Isotech Website.



## Thermocouple Measurements

When used with an external 0°C cold junction reference unit (or by measuring the junction temperature with a PRT on another channel) the microK can be used for low uncertainty precision thermocouple measurements. The microK is designed for ALL the thermometer types used in a laboratory including Standard Thermocouples. The

voltage uncertainty is 0.25µV, equivalent to 0.01°C for a Platinum / Gold thermocouple at 1000°C.

When measuring the voltage from a thermocouple, it is common practice to reverse the input terminations and repeat the measurement in order to detect and/or compensate for any thermal EMFs or offsets

inherent to the voltmeter instrument and its terminals. In the microK the input connections are automatically reversed immediately behind the input terminals. The user can, of course, still reverse the connections manually to gain confidence in the instrument, but it is no longer necessary to achieve low measurement uncertainty.

## Keep Warm Currents

The microK includes keep-warm current sources to maintain the power in a PRT when it is not being measured, eliminating uncertainty resulting from power coefficients. Each channel, whether on the microK or a microsKanner can be individually programmed.

## Zero Current Resistance

The microK was the first Bridge to have the ability to automatically compute and display the zero current resistance with no manual correction, this feature is available on the microK 70 and 125 models.

## Low Noise

The new ADC, together with the low noise pre-amplifiers used in the microK, means you achieve a lower measurement uncertainty in a shorter time. See the document "Noise Performance of microK 100" available on the Isotech website.

# Understanding Specifications

It can be difficult to compare the published specifications from different manufacturers as there seems no common agreement on how to present the data. As Bridges can be used in different ways, tested in different ways and have different features confusion can easily arise. Some specifications separate accuracy, linearity and noise. Some specify a figure only at the Water Triple Point (Unity Ratio) others over ranges. At Isotech we want to present a clear picture of what can be expected from a microK and are proud that independent evaluation has shown the microK to be working to better than our published specifications.

We specify the accuracy in ppm over the whole range of the SPRT, for a microK 70 this 0.07ppm. It is given at  $k=2$ , 2 Sigma 95% confidence level.

We think this is a relevant, simple and transparent way of specifying the performance.

Take an example, a Primary Laboratory with a 25.5Ω SPRT and external 100Ω reference resistor. In such a situation 0.05ppm equates to  $5\mu\Omega$  or 0.05mK over the whole range. If we specify the accuracy just at the water triple point (a 25.5 Ohm SPRT used with a 25 Ohm Standard Resistor); then an error of 0.05ppm is equivalent to a resistance of  $2.5\mu\Omega$ , for a 25.5Ω SPRT, which is equivalent in

temperature to 0.0125mK (12.5μK). Note that whilst we have specified a single value over the whole range the performance will be better close to zero and unity ratio see table below.

Some other manufactures show figures only at the water triple point or unity gain ratio, some publish ratio accuracy valid only for a narrow operating condition. So it is important when comparing specifications to understand what is actually being stated.

| Resistance Ratio Accuracy, 95% Confidence Level (Zero Drift) | microK 70 | microK 125 |
|--|-----------|------------|
| Ratio: 0.0 to 0.25   | 0.017ppm  | 0.03ppm    |
| Ratio: 0.25 to 0.5   | 0.07ppm   | 0.125ppm   |
| Ratio: 0.5 to 0.95   | 0.07ppm   | 0.125ppm   |
| Ratio: 0.95 to 1.05  | 0.017ppm  | 0.03ppm    |

# Ease of Calibration

Only the internal reference resistors and thermocouple voltage reference need calibrating, the procedure is both open and documented. No special equipment is needed other than a suitable voltage source (for the thermocouple side) and Standard Resistors (for internal resistors). Suitable Standard Resistors are available from Isotech.

For ratio measurement the microK

is drift free, not only will it never need adjustment there is nothing to adjust, no trim pots, no software adjustments. The performance can be verified with complement and reciprocal tests using reference resistors or ideally (as with all ratio bridges) using the RBC "Ratio Bridge Calibrator" developed by Rod White at the Measurement Standards Laboratory, New Zealand and now licensed to and available from

Isotech. See paper, "A Method for Calibrating Resistance Thermometry Bridges", White D. R., available on the Isotech website.

After manufacture all the microK models are fully tested with an RBC to confirm linearity over the whole range.



## < Expandable

The microK has three input channels, to allow best practice of having two standard thermometers and still have a channel free for the thermometer under test. Additional expansion channels can be added in blocks of 10 to a maximum of 90 expansion channels. The microKanner adds no additional uncertainty and each channel is individually programmable from the touch screen. Any channel can be set for any thermometer type or for an external resistor.



# Measurement Speed

The microK makes fast sub ppm measurements at a rate of <2s per channel (1s using the RS232 or GPIB interface). Compared to an AC Bridge the microK uses a different filtering system, rather than adjusting a bandwidth filter the number of samples per reading can be adjusted. The table gives an indication of how these compare.

| AC Bandwidth Setting | Time to take single (S) measurement | Equivalent microK Samples / Reading (S) |
|----------------------|-------------------------------------|---|
| 0.02 Hz              | 50                                  | 25                                      |
| 0.1 Hz               | 10                                  | 5                                       |
| 0.5 Hz               | 2                                   | 1                                       |

When using a microK with a scanner it makes measurements more quickly than an AC Bridge. This is because as the AC Bridge has the input opened it goes into a different mode and can take 2 - 3 minutes to fully settle after the transitions. As the microK uses a substitution technique (it is switching at several times a second) it does not need time to recover and is faster in multiplexing applications.

# Noise Immunity

A further design goal was to ensure the microK has excellent EMC (electromagnetic compatibility) performance in terms of radiated emissions and immunity from electromagnetic interference not just to ensure compliance to

International EMC Directives but to allow the microK to make <0.1ppm measurements in a real world environment. Extensive testing was made with long cables attached to both the inputs and PC interfaces, the requirements being that such

loads should not affect the readings. As a result the microK has superior specification to older design bridges that it has replaced.

# Internal and External Resistors

The instrument has internal reference resistors which allow a wide range of resistance thermometers to be used with a microK without the need for an external resistor. The use of an external or internal resistor depends both on the mode of use and the required uncertainty.

Consider an example; comparison calibration of SPRTs. In this case best practise is to directly compare the Standard Thermometer with the thermometer under test. The uncertainty is largely determined by the calibration of the Standard Thermometer and no reference resistor is needed, either external or internal.

A benefit of the microK over a traditional bridge is that by using one of the internal standards the microK can be programmed to display either the temperature or resistance of the standard probe along with the ratio of the thermometer under test to the standard. Again in this application an external resistor is not required. The value of the reference resistor is not important when comparing thermometers as long as it is stable during the period of the measurement, which is just a few seconds. Providing that the thermometers all have the same shape of resistance to temperature curve any change in the reference resistor from its original calibration are

negated as the shift in the thermometer under test will be equivalent to the shift in the standard.

Another example; if an NMI is using a microK to disseminate the ITS-90 temperature scale and make absolute measurements at fixed points then a temperature controlled external standard resistor should be used in line with good laboratory practise.

For applications in between it is necessary to consider the specification of the internal reference resistors with the required uncertainty.

## Cable Pod Connectors >

The gold plated connectors accept 4mm plugs, spades or bare wires. The 3/4" separation is compatible with standard 4mm to BNC adaptors, so you can use thermometers with any normal termination type. The Cable Pod™ connector system uses gold plated tellurium-copper to give the lowest possible thermal EMF and the best measurement uncertainty. The connectors have a clamping arrangement that does not rotate as the terminal is screwed down, thereby protecting the wire from mechanical damage.



## What are the advantages of the microK over conventional ratio bridges?

- Can work with thermocouples as well as resistance thermometers
- Simple Touch Screen operation with easy to use interface and data logging options
- Can connect USB Memory Stick, Keyboard, Mouse
- Built in database for all your thermometers and reference resistors
- The microK does not use tapped transformers restricting its measurement range
- Wide range of resistance, 0 - 500 k $\Omega$
- No Moving Parts
- Displays Temperature, Resistance and Ratio
- Statistical Mode
- Chart Display
- Plug and Play Channel Expanders, control up to 92 channels from the touch screen
- No PC needed, the display can show temperature and resistance in addition to ratio
- Cost Saving

## microK or AC Bridge?

The sense current in the microK's bridge circuit is a square wave AC signal. This measurement system is usually referred to as a switched DC bridge (the term AC Bridge is normally reserved for bridges that use a sinusoidal sense current). The new techniques used in the microK overcome the limitations of earlier designs, matching the performance of the best AC Bridges whilst offering a number of advantages, not least zero drift.

## Drift

AC Bridges utilise an inductive divider, which is drift free as the turns ratio on a transformer is a constant. However, leakage flux means that AC Bridges do not inherently provide a unity ratio reading with a 1:1 turns ratio. So a correction circuit is employed to compensate, and this correction circuit is adjusted with a tweak pot. Additionally AC bridges use many tens of potentiometers that are set up during manufacture in order to align internal filters and null out offsets. During transportation and over time these can drift out of adjustment and a specialist engineer is needed to make internal adjustments to the AC Bridge.

In comparison the microK has no potentiometers, no select on test components or software offsets -in ratio measurement it is *inherently drift free by design*.

## Noise

It has been claimed that AC Bridges have the best noise performance but again the microK's innovative design sets new standards. Firstly all the microK family utilise a fast ADC that allows the sense current reversal to operate at 6-10Hz avoiding the 1/f flicker noise of many conventional switched DC systems.

Secondly to match the performance of the most sophisticated (and expensive) AC Bridges a new technique of Parallel Analogue Processing was developed for the microK 70 and microK 125 models.

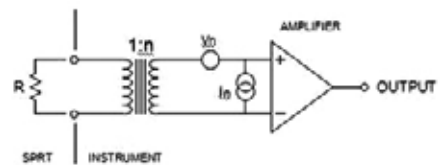

*Noise Impedance Matching in AC Resistance Bridges*

The best AC bridge designs use "noise impedance matching" to minimise the noise contribution of the semiconductors used in the amplifier. Since the waveforms in an AC bridge are sinusoidal, a transformer can be used at the input to the amplifier to reduce input noise at the expense of voltage noise.

This noise reduction technique can only be used with an AC resistance bridge (it cannot be used in switched DC bridges or DC current-comparator bridges) and this is one of the reasons that AC resistance bridges have historically been



## < Parallel Analogue Processing

In developing the microK a new technique of Parallel Analogue Processing is used to reduce the voltage noise to a level that was only previously achievable using the best AC resistance bridges.

seen as the instrument of choice for primary standards temperature metrology.

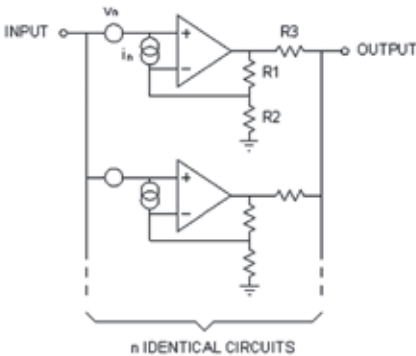

Noise Reduction by Parallel Analogue Processing

In developing the microK a new technique of Parallel Analogue Processing was devised to reduce the voltage noise to a level that was only previously achievable using the best AC resistance bridges.

Each amplifier contributes linearly to the desired output signal. However, the noise from each amplifier contributes as the RMS (root of the mean squares), which is less than the linear summation of the signals. In a similar way to the noise impedance matching technique used in AC resistance bridges, the microK design is able to reduce voltage noise at the expense of current noise by using a number of amplifiers connected in parallel (increasing  $n$ ).

## Elimination of Thermal EMF

Like an AC Bridge the microK eliminates the effect of thermal EMFs (EMFs generated as the result of dissimilar metals and temperature gradients) by taking two measurements ( $V_1$  and  $V_2$ ) and reversing the current ( $I$ ) between them.

The process of current reversal and averaging, together with true 4-wire resistance measurement has the effect of eliminating thermal EMF and of ensuring an intrinsically stable zero with time and temperature.

## Line Frequency Rejection

As the microK range of instruments uses digital filters these provide 100% or complete rejection of 50Hz and 60Hz. Other instruments may use analogue filters which provide finite rejection but the digital filters used in microK's provide complete rejection.



### Three Input Channels >

Best practice guidelines recommend the use of two reference thermometers for calibrations. That is why we have included three channels in the microK, enabling you to achieve best practice without having to buy additional and costly multiplexers. Other benefits are when calibrating SPRTs in Fixed Point Cells, the third channel can be connected to a monitor SPRT to check the standard resistor. When intercomparing ITS-90 cells two SPRTs are exchanged to get accurate temperature differences - the third channel allows the two SPRTs to be compared to a reference resistor.





# microKanner: Channel Expander

The microKanner can be used with any member of the microK family to add further channels, up to a maximum of 90 expansion channels.

**Easy to Use:** The use of plug-and-play technology means that the extra channels appear automatically on your microK bridge when connected to a microKanner. You can configure the new input channels in exactly the same way as any of the microK's existing inputs (through the microK's touch screen or a PC, via an RS232 connection). You just plug in a microKanner and immediately gain the benefit of the additional channels, making this the easiest channel expansion system of its type.

**Accurate:** The microKanner replicates the input system of the microK bridge for all 10 of its input channels. Measurements made with a microKanner are therefore to the same accuracy as the microK bridge it is connected to. By adding further scanners the microK system can be expanded to 92 channels without losing measurement performance.

**Versatile:** Like the microK bridge, the microKanner works with PRTs, thermocouples and thermistors giving you unparalleled flexibility.

**Keep-Warm Currents:** The microKanner has 10 individually programmable keep-warm current sources to maintain the power in PRTs when they are not being measured, eliminating uncertainty caused by power coefficients.

**Cable Pod™ Connector System:** The connectors accept 4mm plugs, spades or bare wires. The standard



$\frac{3}{4}$ " separation is compatible with standard 4mm to BNC adaptors, so you can use thermometers with any standard termination type. The Cable Pod™ connector system uses gold-plated, tellurium-copper to give the lowest possible thermal EMF and the best measurement uncertainty.

**Reliable:** Like the microK, the microKanner uses the latest semiconductor technology for channel selection and signal routing. This completely solid-state design therefore provides the highest possible reliability.

|                      |  |
|----------------------|--|
| Model                | microKanner  |
| Channels             | 10   |
| Keep-Warm Currents   | 0-10mA $\pm$ 0.4% of value, $\pm$ 7 $\mu$ A, resolution 2.5 $\mu$ A                                |
| Input connectors     | Cable Pod™ connector accepting: 4mm plugs, spades or bare wires                                    |
| Contact material     | Gold plated tellurium copper   |
| Interface            | RS232 (9600 baud)  |
| Operating conditions | 15-30°C / 50-85°F, 10-90% RH (for full specification)<br>0-50°C / 32-120°C, 0-99% RH (operational) |
| Power                | 88-264V (RMS), 47-63Hz (Universal)<br>10W maximum, 1.2A (RMS) maximum                              |
| Size                 | 520mm x 166mm x 300mm /<br>20.5" x 6.6" x 11.9" (W x D x H)  |
| Weight               | 12.6kg / 28lb  |

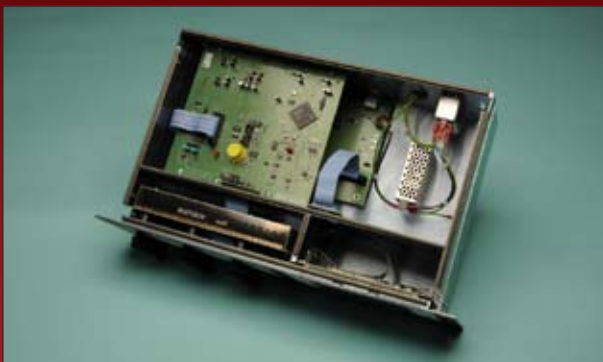

## < Reliable

Before the microK, instruments with this level of performance had to use mechanical relays. The microK breaks the mould by using the latest semiconductor devices to provide a completely solid state solution. To reduce the component count high density silicon integration technology is used (FPGA). If you have ever seen inside another instrument in this performance class you may have been concerned about long term reliability and servicing cost. Compare this with the inside of the microK



# microKanner

- Performance - zero uncertainty contribution
- Flexibility - supports all sensor types (PRTs, thermocouples & thermistors)
- Keep-warm currents for PRTs - individually programmable
- Ease of use - plug-and-play... new channels added by the microKanner just appear in the existing operator interface on the microK
- Input channels - up to 90 expansion channels
- Reliability - completely solid-state (no relays)



## PC Interfaces >

All the microK models have USB Host, RS232 Serial and now IEEE-488 GPIB (General Purpose Interface Bus). The microK is compatible with Isotech I-Cal EASY software and is easily controlled from either the RS232 or IEEE port. The command set uses the SCPI (Standard Commands for Programmable Instruments) protocol. Any microKanners are controlled via the microK port, easing automation - no separate connection from the PC to the scanners is necessary. The microK 70 and 125 models also feature an Ethernet port and the microK desktop can be controlled across a LAN or WLAN allowing remote control and monitoring from either a PC in the lab, or should you choose, from anywhere in the world.



# microK Universal Specifications

|                                       |  |                              |  |
|---------------------------------------|--|------------------------------|--|
| <b>Accuracy - Thermocouples</b>       | Voltage uncertainty:<br>Range 0-20mV 250nV<br>Equivalent to 0.01°C for Gold<br>Platinum thermocouples at 1000 °C                             | <b>Expandable</b>            | Add up to 90 expansion channels  |
| <b>Measurement Time (Per Channel)</b> | <b>Resistance:</b> <2s (1s using the RS232 or GPIB interface)<br><b>Voltage:</b> <1s (0.5s using the RS232 or GPIB interface)                | <b>Probes Supported</b>      | PRT's, Thermistors & Thermocouples   |
| <b>Temperature Conversions</b>        | PRTs: ITS-90, Callendar-van Dusen. Thermocouples: IEC584-1 1995 (B, E, J, K, N, R, S, T), L and gold-platinum<br>Thermistors: Steinhart-Hart | <b>Units</b>                 | Ratio, V, Ω, °C, °F, K   |
| <b>Cable Length</b>                   | Limited to 10Ω per core and 10nF shunt capacitance (equivalent to 100m of RG58 coaxial cable)  | <b>Switching Technology</b>  | Solid state  |
| <b>Input Connectors</b>               | Cable Pod™ connector accepting: 4mm plugs, spades or bare wires<br>Contact material: gold plated tellurium copper                            | <b>Sensor Current</b>        | 0 – 10mA in 3 Ranges<br>0 – 0.1mA ±0.4% Value<br>±70nA (Resolution 28 nA)<br>0.1 – 1mA ±0.4% Value<br>±0.7µA (Resolution 280nA)<br>1– 10mA ±0.4% Value<br>±7µA (Resolution 2.8 µA) |
| <b>Interfaces</b>                     | RS232 (9600 baud)<br>IEEE-488 GPIB<br>USB (1.1) - host   | <b>Keep Warm Current</b>     | Adjustable 0-10mA<br>Each Channel Adjustable<br>0-10mA ±0.4% Value ±7µA<br>(Resolution 2.8 µA)   |
| <b>Ratio Range</b>                    | Unlimited  | <b>Internal Data Storage</b> | 2Gb: For > 4 years storage<br>(Timed Stamped Measurements)   |
| <b>Display</b>                        | 163mm / 6.4" VGA (640 x 480)<br>Colour TFT LCD   | <b>Operating Conditions</b>  | <b>For Full Specification:</b><br>15 - 30°C 10 - 80% RH<br><b>Operational:</b><br>0 - 40°C 0 - 95% RH  |
| <b>Channels</b>                       | 3  | <b>Supply</b>                | 88-264 Vac, 47-63Hz  |
| <b>Cold Junction Mode</b>             | External and Remote with PRT   | <b>Size W x D x H</b>        | 520mm x 166mm x 300mm /<br>20.5" x 6.6" x 11.9"<br>(19" Rack Mountable)  |



## < Ease of Use

The microK includes a comprehensive range of features, including direct reading in temperature for all sensor types, data logging, easy export of data to Excel™ and graphing facilities. Despite its sophistication the microK is very easy to use. The built in full VGA colour touch screen has a powerful and intuitive operator interface so you can get on with making measurements rather than learning how to control the instrument. A USB port allows data to be exported, or logged to a USB Memory Stick. To help with data entry a standard USB mouse / keyboard can be added.

# microK Specifications (Specifications are subject to change without prior notice)



| Parameter  | microK 70                                      | microK 125             | microK 250   | microK 500                   |
|--|--|------------------------|--|------------------------------|
| Accuracy Whole Range (SPRT $R_o \geq 2.5\Omega$ ) <sup>[1]</sup> | 0.07ppm  | 0.125ppm               | 0.25ppm  | 0.5ppm                       |
| Accuracy Ratio 0.95 to 1.05 <sup>[2]</sup>                       | 0.017ppm                                       | 0.03ppm                | 0.06ppm  | 0.125ppm                     |
| Equivalent Temperature Accuracy <sup>[2]</sup>                   | 0.017mK  | 0.03mK                 | 0.06mK   | 0.125mK                      |
| Resolution   | 0.001mK  | 0.001mK                | 0.01mK   | 0.01mK                       |
| Resolution Voltage   | 10nV   | 10nV                   | 10nV   | 10nV                         |
| Stability  | 0ppm/yr <sup>[3]</sup>                         | 0ppm/yr <sup>[3]</sup> | 0ppm/yr <sup>[3]</sup>   | 0ppm/yr <sup>[3]</sup>       |
| TC (resistance ratio) <sup>[4]</sup>                             | 0ppm/°C <sup>[3]</sup>                         | 0ppm/°C <sup>[3]</sup> | 0ppm/°C <sup>[3]</sup>   | 0ppm/°C <sup>[3]</sup>       |
| Resistance Range   | 0 - 100 k $\Omega$                             | 0 - 100 k $\Omega$     | 0 - 500 k $\Omega$   | 0 - 500 k $\Omega$           |
| Voltage Range (Thermocouple)                                     | $\pm 125$ mV                                   | $\pm 125$ mV           | $\pm 125$ mV   | $\pm 125$ mV                 |
| Internal Resistance Standards                                    | 25, 100, 400 $\Omega$                          | 25, 100, 400 $\Omega$  | 1, 10, 25, 100, 400 $\Omega$   | 1, 10, 25, 100, 400 $\Omega$ |
| Internal Standard Resistor Stability                             | TCR <0.05ppm/°C<br>Annual Stability <2ppm/year |                        | 1, 10 $\Omega$ <0.6ppm/°C <5ppm/year<br>25,100,400 <0.3ppm/°C <5ppm/year |                              |
| Interfaces   | RS232, GPIB & USB & Ethernet                   |                        | RS232, GPIB, USB   |                              |
| Power  | 25W maximum, 1.5A (RMS) maximum                |                        | 20W maximum, 1.5A (RMS) maximum  |                              |
| Weight   | 13.3kg   | 13.3kg                 | 12.4kg   | 12.4kg                       |

- Notes:**
- Over whole range of SPRT, -200°C to 962°C. For  $R_o=0.25\Omega$  increased by a factor of 2.5
  - E.g.: 25 $\Omega$  SPRT with 25 $\Omega$  standard resistor at water triple point or with direct comparison of similar SPRTs.
  - The microK uses a "substitution technique" in which the Device-Under-Test and the Reference are successively switched into the same position in the measuring circuit. This means that the stability of resistance ratio measurements is immeasurably small.
  - Using external reference resistors.

## Web Links >

Using a Substitution Measurement Topology to Eliminate the Effect of Common Mode Errors in Resistance Measurements used in Temperature Metrology

Better Accuracy in Temperature Calibration and Measurement through a New Type of Analog-to-Digital Converter

Noise Performance of microK 100

A Method for Calibrating Resistance Thermometry Bridges, White D. R.

Quick Link: <http://isotech.info/microK/documents>





